

ELEVATE YOUR PACKAGING CAPABILITIES

GS-90 Tamp-Blow Label Applicator

The Gold Seal® GS-90T is a state-of-the-art compact, value-packed label applicator that's ideal for stand-alone or integrated, industrial or consumer labeling.

No adjustments!

All-Steel

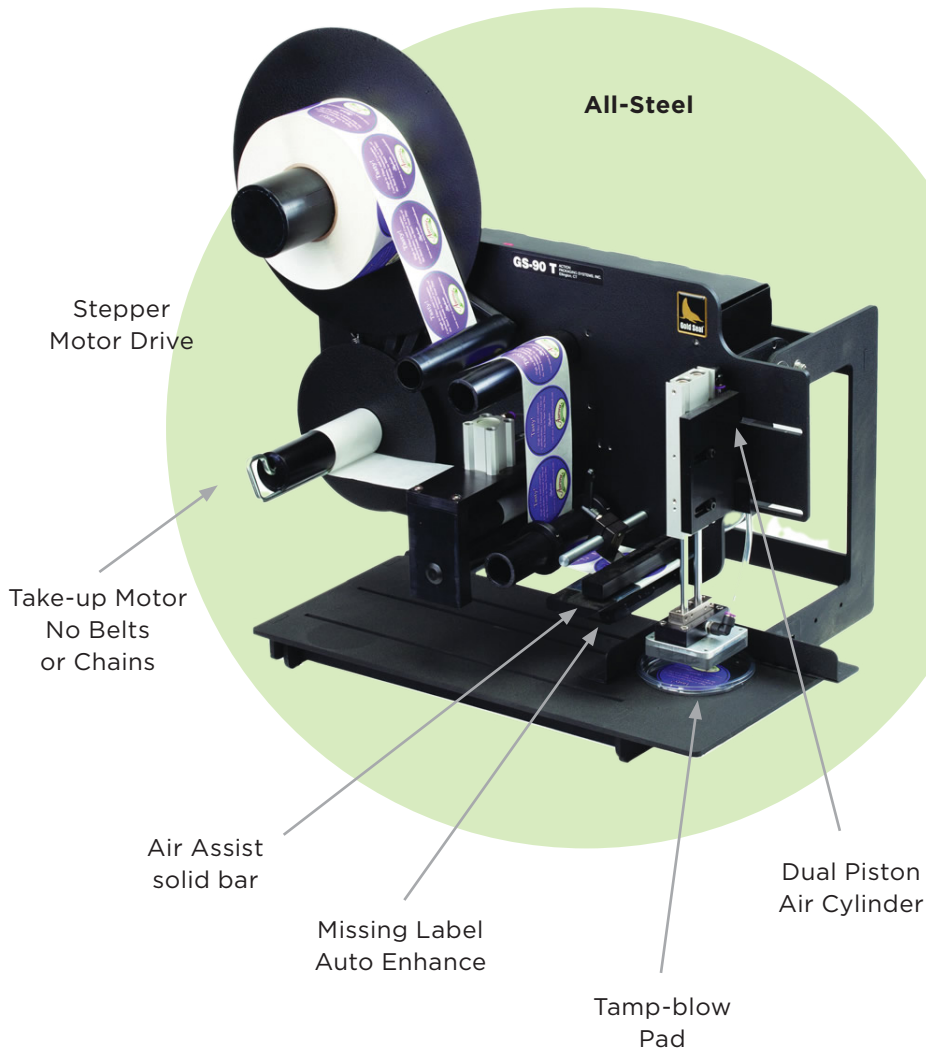

WHY CHOOSE FORTIS?

All techs are fully trained and certified by each manufacturer.

Consistent and accurate label application time and time again.

Save space; small footprint with options to integrate into existing lines.

Opportunities to finance applicators through our labels BOOST program.

DIMENSIONS

GS-90:
26"W x 22"H x 14"D

With fixture base:
26"W x 24-1/2"H x 22"D

With T-stand:
45"W x 54"H x 34"D D

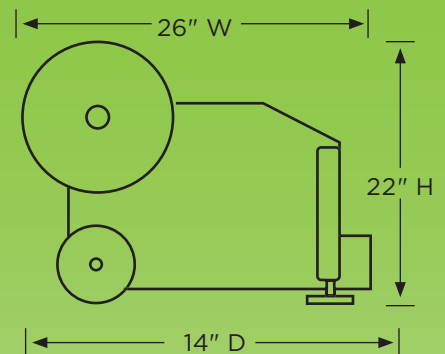

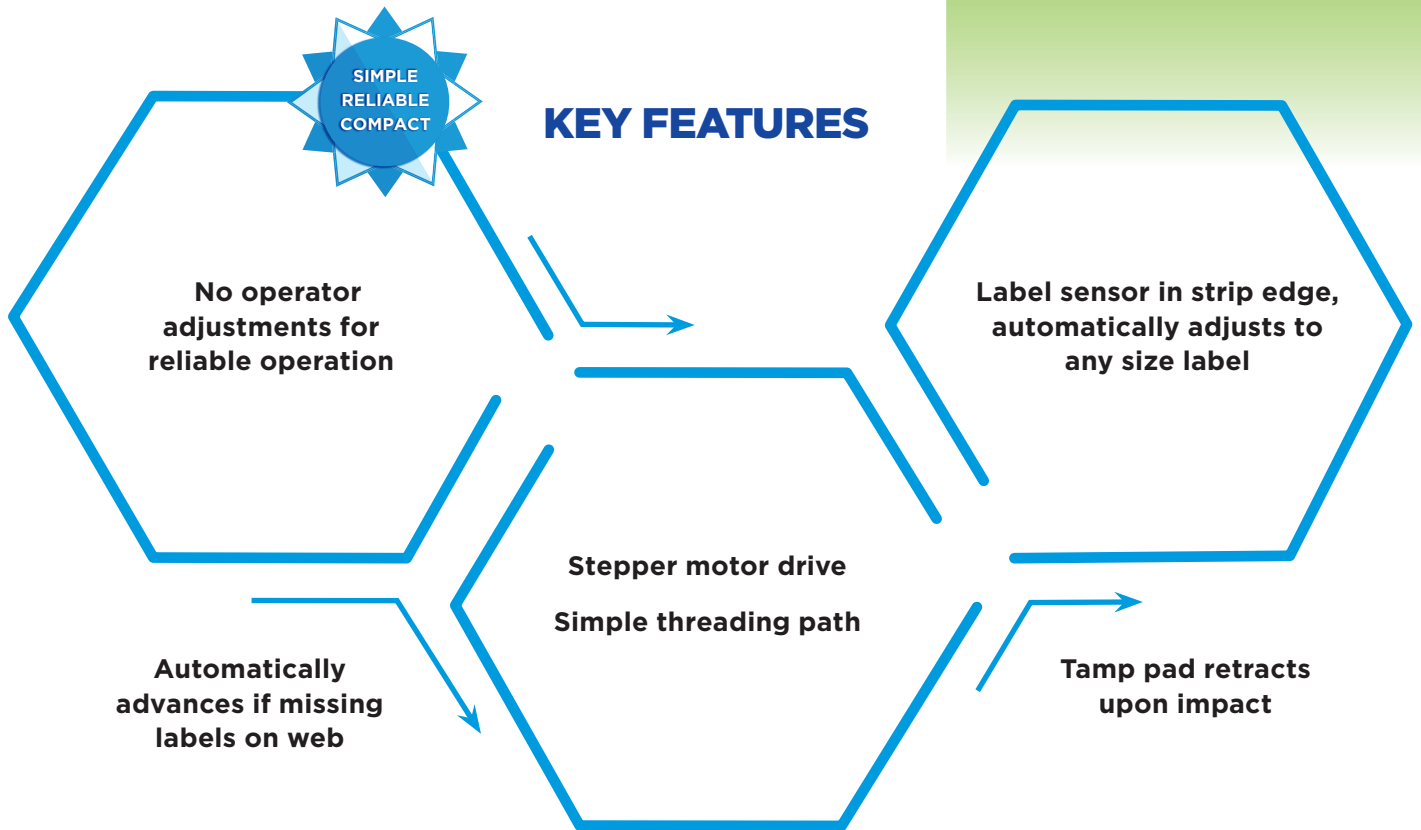

APPLICATOR SPECIFICATIONS

Label Dimensions - Width: 1/2" - 5" Length: 1/2" - 10"

Accuracy - Plus or Minus 1/64th" Tamp-blow

Outside Roll Diameter - 12" Label Core Diameter: 3"

Product Sensing - Photoelectric

Label Sensing - Photoelectric

Air - 40 lbs.

Electric - 110-120 VAC

AVAILABLE OPTIONS

Low Label Light Tower

Product Fixture Base

Adjustable Support Stand

So easy to operate, it is "second-shift proof"

Contact Us Today

for a site survey so we can determine the perfect Applicator for your needs!

Reach out to your Fortis Solutions Group Representative.

Or call: **1-844-765-8867**

applicators@fortissolutionsgroup.com

fortissolutionsgroup.com

© Fortis Solutions Group, 9/25