

ELEVATE YOUR PACKAGING CAPABILITIES

GS-60 Printer Applicator

The Gold Seal® GS-60 is a state-of-the-art, compact, value-packed thermal transfer printer applicator with fixture or conveyor-mounted. Ideal for stand-alone or integrated, industrial or consumer labeling and coding operations.

No adjustments!

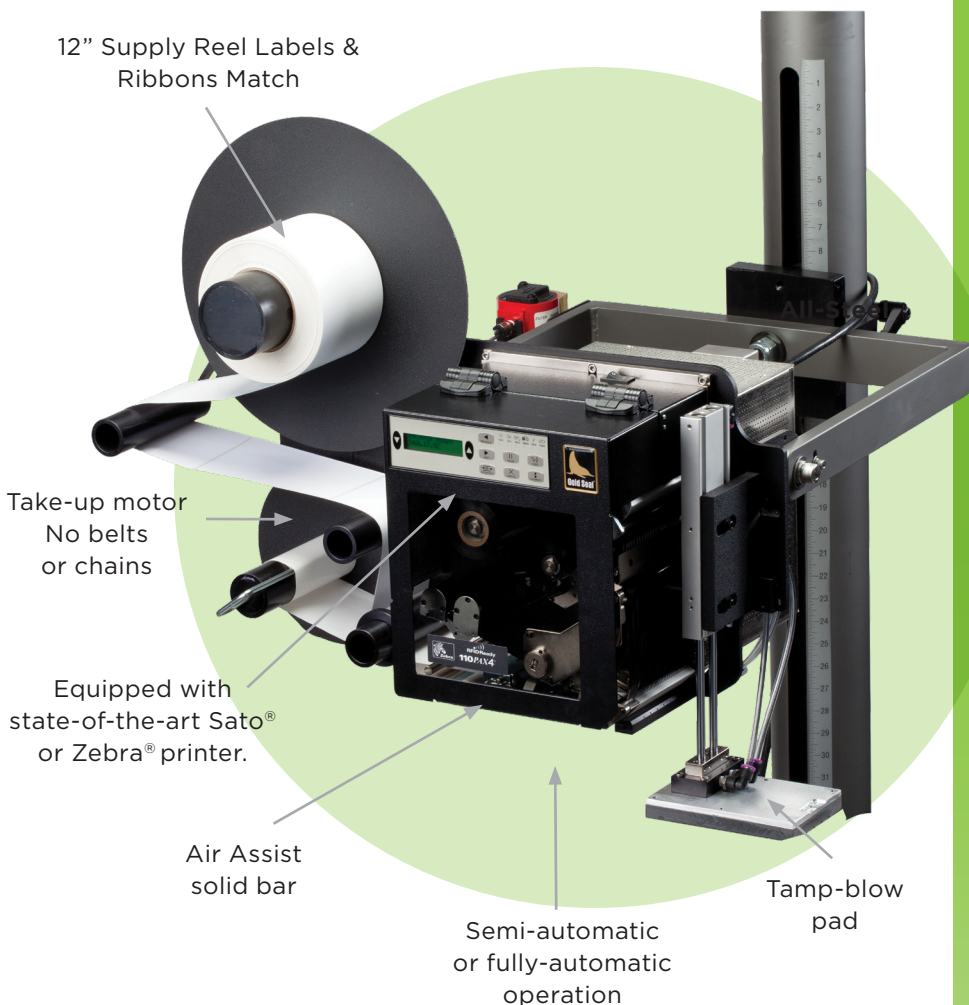

WHY CHOOSE FORTIS?

All techs are fully trained and certified by each manufacturer.

Consistent and accurate label application time and time again.

Save space; small footprint with options to integrate into existing lines.

Opportunities to finance applicators through our labels BOOST program.

DIMENSIONS

GS-60:
26" W x 18" H x 16" D

With fixture base:
26" W x 24-1/2" H x 22" D

With T-stand:
45" W x 54" H x 34" D

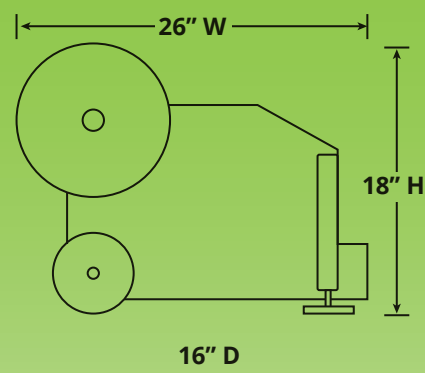

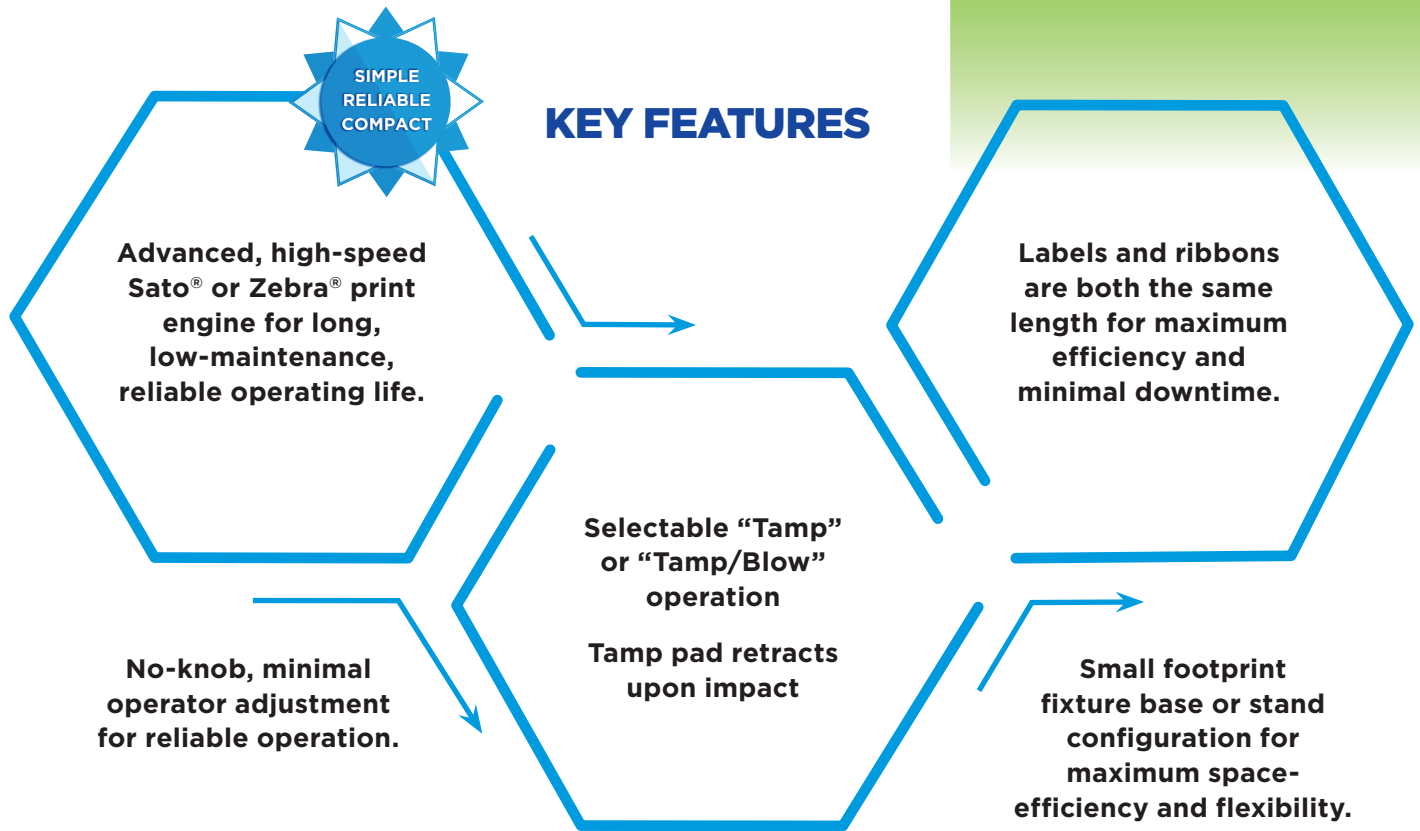

APPLICATOR SPECIFICATIONS

- Plug-in Interface Modules
- 10/100 Base@T Ethernet, USB
- Wireless
- Label Core Diameter: 3"
- Label Roll Diameter: 12" O.D.
- Label & Ribbon Length 1,345' (Sato), 1,476' (Zebra)
- Utilities: 110-120 VAC; 60 psi dry air @ 3 cfm

MODEL	ZE511	ZE521	S84NX	S6NX
Resolution	203 dpi/8 dots per mm Options: 300 dpi/12 dots per mm; 600 dpi/24 dots per mm	203 dpi/8 dots per mm Option: 300 dpi/12 dots per mm	203 or 305 or 609 dpi	203 or 305 or 609 dpi
Print Width	4.09"	6.6"	4.1"	6.6"
Print Speed	18 ips/457 mm per second @ 203 dpi	14 ips/356 mm per second @ 203 dpi	16 ips - 203 dpi	14 ips - 203 dpi
Print Speed	14 ips/356 mm per second @ 300 dpi	12 ips/305 mm per second @ 300 dpi	14 ips - 305 dpi	12 ips - 305 dpi
Print Speed	6 ips/152 mm per second @ 600 dpi		6 ips - 609 dpi	

Contact Us Today

for a site survey so we can determine the perfect Applicator for your needs!

Reach out to your Fortis Solutions Group Representative. Or call: **1-844-765-8867**

applicators@fortissolutionsgroup.com

fortissolutionsgroup.com